

ROUTINE

MWO effective date is 1 January 2001 and completion date is 31 December 2004.

MWO 9-2320-280-20-6

MODIFICATION WORK ORDER

MODIFICATION OF 1-1/4 TON VEHICLES

HEAVY VARIANT, ARMAMENT CARRIER, AND
EXPANDED CAPACITY VEHICLES
M1097, M1097A1, M1025A2,
M1097A2, M1113, AND M1114

AIRLIFT BUMPER REINFORCEMENT

Headquarters, Department of the Army, Washington, D.C.

1 January 2001

REPORTING OF ERRORS AND RECOMMENDING IMPROVEMENTS

You can help improve this publication. If you find any mistakes or if you know of a way to improve the procedures, please let us know. Submit your DA Form 2028-2 (Recommended Changes to Equipment Technical Publications), through the Internet, on the Army Electronic Product Support (AEPS) website. The Internet address is <http://aeprs.ria.army.mil>. If you need a password, scroll down and click on "ACCESS REQUEST FORM". The DA Form 2028 is located in the ONLINE FORMS PROCESSING section of the AEPS. Fill out the form and click on SUBMIT. Using this form on the AEPS will enable us to respond quicker to your comments and better manage the DA Form 2028 program. You may also mail, fax or E-mail your letter, DA Form 2028 or DA Form 2028-2 direct to: Commander, U.S. Army Tank-automotive and Armaments Command, ATTN:AMSTA-LC-CIP-WT, Rock Island, IL 61299-7630. The email address is TACOM-TECH-PUBS@ria.army.mil. The fax number is DSN 793-0726 or Commercial (309) 782-0726.

APPROVED FOR PUBLIC RELEASE; DISTRIBUTION IS UNLIMITED.

1. PURPOSE.

This modification provides a reinforcement for the bumper during towing operations. After the vehicle is modified it will be "AUTHORIZED TO TOW TRAILERS WITH MAX GROSS WEIGHT OF 4,200 LB (1,907 KG)".

2. PRIORITY.

This modification is classified as ROUTINE.

3. END ITEM TO BE MODIFIED.

NOTE

Application will be controlled/determined by PM, LTV based on approved DCSOPS distribution plans/funding streams for HMT.

a. Selected vehicles as identified by models below and serial numbers selected by the user.

NOMENCLATURE	NSN	PART NO.	CAGEC	MODEL NO.
Truck, Utility, 1-1/4 ton, 4x4: Armament Carrier, Armored	2320-01-380-8233	8750309	19207	M1025A2
Truck, Utility, Heavy Variant 1-1/4 ton 4x4: *Heavy Variant	2320-01-346-9317	8750236	19207	M1097
*Heavy Variant	2320-01-371-9582	8750308	19207	M1097A1
*Heavy Variant	2320-01-380-8604	8750315	19207	M1097A2
Truck, Utility, Expanded Capacity 4x4: *Shelter Carrier	2320-01-412-0143	87T0014	19207	M1113
Up-Armored Carrier	2320-01-413-3739	87T0015	19207	M1114

*Not applicable to vehicles equipped with Pintle Extension Kit, or not applicable to vehicles with shelters extending past the rear bumper.

b. Vehicle National Stock Number (NSN) will not change as a result of this MWO.

4. MODULE(S) TO BE MODIFIED.

Not applicable.

5. PART(S) TO BE MODIFIED.

Not applicable.

6. APPLICATION.

a. Time Compliance Schedule: The effective date of this MWO is 1 January 2001 and its completion date is 31 December 2004.

b. The lowest level of maintenance authorized to apply the MWO is Organizational maintenance.

c. Work force and man-hour requirements for application of the MWO to a single unit, end item, or

REQUIREMENTS	
WORK FORCE/SKILLS	MAN-HOURS
One Wheeled Vehicle Mechanic (MOS 63B) or equivalent	0.8
Total man-hours required for a single application of this MWO	0.8

system:

7. TECHNICAL PUBLICATIONS AFFECTED/CHANGED AS A RESULT OF THIS MWO.

<u>Technical Publication</u>	<u>Date</u>
TM 9-2320-280-10	31 Jan 96
TM 9-2320-280-20	31 Jan 96
TM 9-2320-280-24P	31 Jan 96
TM 9-2320-387-10	31 Oct 97
TM 9-2320-387-24	31 Nov 97
TM 9-2320-387-24P	31 Sep 98

8. MWO KITS, PARTS, AND THEIR DISPOSITION.

a. The following kit is required to accomplish this modification. The security classification of this kit is unclassified. Shipping data is: weight 32 lbs; the kit measures 31.5 x 9 x 3 in.; its volume is 0.492 cu ft.

<u>NSN</u>	<u>NOMENCLATURE</u>	<u>CAGEC</u>	<u>PART NO.</u>
5340-01-477-6588	Airlift Bumper Reinforcement Modification Kit	19207	57K3554

b. Airlift Bumper Reinforcement Modification Kit component parts are listed below. The listing is used to inventory the kit for completeness.

<u>NSN</u>	<u>NOMENCLATURE</u>	<u>CAGEC</u>	<u>PART NO.</u>	<u>QTY.</u>
9905-00-858-5682	Plate, Instruction, MWO	19207	10930014	1
	Plate, Bumper Reinforcement	19207	12469169	1
	Bracket, Pintle	19207	12469170	1
4730-00-050-4207	Fitting, Lube	96906	MS15001-4	1
5305-00-253-5614	Screw, Drive	96906	MS21318-20	1
5315-00-846-0126	Pin, Cotter	96906	MS24665-628	1
	Nut	81349	M45913/4-8CG8Z	8
5310-01-152-0598	Nut	24617	271172	6
	Screw	80204	B1821BH025C150N	4
	Screw	80204	B1821BH050C300N	4
5305-00-071-2077	Screw	80204	B1821BH050C350N	4

c. Bulk and Expendable Material.

<u>NSN</u>	<u>NOMENCLATURE</u>	<u>CAGEC</u>	<u>PART NO.</u>	<u>QTY.</u>
	Adhesive: Versilok	6W728	204	A/R

d. Parts Disposition. All parts not reused during installation will be returned to stock for disposition in accordance with AR 725-50.

9. SPECIAL TOOLS; TOOL KITS; JIGS; TEST, MEASUREMENT, AND DIAGNOSTIC EQUIPMENT (TMDE); AND FIXTURES REQUIRED.

a. Hand tools necessary to apply MWO are contained in following tool kit:

<u>NOMENCLATURE</u>	<u>NSN</u>	<u>CAGEC</u>	<u>SUPPLY CATALOG</u>
---------------------	------------	--------------	-----------------------

Tool Kit, General Mechanic's 5180-00-177-7033 50980 SC 5180-95-N26

b. Tools necessary to apply MWO are contained in following shop set:

NOMENCLATURE	NSN	CAGEC	SUPPLY CATALOG
Shop Equipment, Automotive Maintenance and Repair: Organizational Maintenance, Common No. 1	4910-00-754-0654	19204	SC 4910-95-A74

10. MODIFICATION PROCEDURE.

a. Vehicle Preparation.

- (1) Park vehicle and apply parking brake lever. (Refer to TM 9-2320-280-10 or TM 9-2320-387-10.)
- (2) Remove towing pintle assembly. (Refer to TM 9-2320-280-20 or TM 9-2320-387-24.)
- (3) Remove four nuts, screws, cover assembly, and trailer connector from receptacle mounting bracket and rear bumper as shown in figure 1.
- (4) Remove two nuts, screws, and receptacle mounting bracket from rear bumper as shown in figure 1.
- (5) Remove four nuts, eight washers, and four screws from rear bumper and bumper mounting brackets as shown in figure 2.

b. Airlift Bumper Reinforcement Installation.

- (1) Install 12469169 bumper reinforcement plate on rear bumper and bumper mounting brackets with four B1821BH050C350N screws, eight existing washers, and four M45913/4-8CG8Z nuts as shown in figure 3. Do not tighten nuts.
- (2) Install MS15001-4 lube fitting in 12469170 pintle bracket as shown in figure 4.
- (3) Install existing safety chain plate, support plate, spacer, and pintle bracket (12469170) on bumper reinforcement plate and rear bumper with four B1821BH050C300N screws, eight existing washers, and four M45913/4-8CG8Z nuts as shown in figure 4. Do not tighten nuts.

c. Vehicle Final Preparation.

- (1) Route trailer connector through existing receptacle mounting bracket and install receptacle mounting bracket on bumper reinforcement plate and rear bumper with two B1821BH025C150N screws and 271172 nuts as shown in figure 5. Do not tighten nuts.
- (2) Install existing cover assembly and trailer connector on receptacle mounting bracket, bumper reinforcement plate, and rear bumper with two B1821BH025C150N screws, two existing screws, and four 271172 nuts as shown in figure 5.
- (3) Install towing pintle on bumper reinforcement plate and rear bumper with existing washer and slotted nut as shown in figure 6. Loosen slotted nut slightly if towing pintle will not rotate easily.
- (4) Align hole in towing pintle and slotted nut and install MS24665-628 cotter pin through slotted nut and towing pintle as shown in figure 6.
- (5) Tighten nuts installed in para. b, steps 1 and 3 to 90 lb-ft (122 N•m) as shown in figures 3 and 4.
- (6) Tighten nuts installed in para. c, steps 1 and 2 to 10 lb-ft (14 N•m) as shown in figure 5.

11. CALIBRATION REQUIREMENTS.

Not applicable to this MWO.

12. WEIGHT AND BALANCE DATA.

Weight and balance are not significantly affected by this MWO.

13. QUALITY ASSURANCE REQUIREMENTS.

a. General. The following information is furnished to ensure the proper application of this MWO and provide clarification in regard to the adequacy of installer's inspection methods and procedures applicable to Quality Assurance (QA). Inspection shall be IAW TM 750-245-4, TM 9-2320-280-10, TM 9-2320-280-20, TM 9-2320-387-10, TM 9-2320-387-24, and MWO 9-2320-280-20-6.

b. Installer Responsibilities. The installer is responsible for following instructions in MWO 9-2320-280-20-6, TM 9-2320-280-10, TM 9-2320-280-20, TM 9-2320-387-10, and TM 9-2320-387-24. The installer will report Airlift Bumper Reinforcement Modification Kits received that are damaged or missing component parts so the kit supplier can be properly notified. Any discrepancies noted will be corrected before the vehicle leaves the installer's work area. Requirements contained in this MWO shall be included in the installer's inspection plan or quality assurance program. These requirements shall not be construed as eliminating the installer's responsibility from complete compliance with provisions of the contract and submitting to the Government products that meet all requirements of the contract.

c. Government Verification. All QA operations and installation changes and inspections performed by the installer are subject to Government verification at unannounced and varying intervals. Verification will consist of observations and inspections to confirm that practices, methods, and procedures of the installer's written inspection plan are being properly applied; and that Government product inspection to confirm the quality of product offered for Government acceptance does not deviate from prescribed acceptance standards specified in TM 9-2320-280-10, TM 9-2320-280-20, TM 9-2320-387-10, TM 9-2320-387-24, and TM 750-245-4. Deviations will be brought to the attention of the installer for correction.

d. In-process Inspection. During normal assembly operations, paragraph 10, Modification Procedure, will be used to check the installer's work. After installation is complete, the vehicle will be checked IAW the PMCS checklist for correct installation and to ensure there are no defects. Any defects noted will be corrected by the installer before the vehicle is placed in service. All vehicles modified during a production shift will be checked to ensure product quality.

14. RECORDING AND REPORTING OF THE MODIFICATION.

a. Records and Reports. The organization responsible for MWO application will report application information as follows:

- (1) Reporting will be accomplished by electronic means. MWO application information can be input directly into the Modification Management Information System (MMIS) over the internet. If internet is not available, recording will be on a 3.5-inch disk, which will be mailed to the MMIS administrator. Entry into the MMIS system is password protected. New users can register online at <http://208.242.67.250/mwo>. Passwords are normally approved and issued within 48 hours.
- (2) Submission will be comprised of the nine (9) data elements listed in the table below. Elements 1,2,4,6,7,8 & 9 are given for this MWO (as shown). The person reporting the MWO data, will acquire the remaining elements (3 & 5), and input all nine into MMIS.

DATA Elements

Input Data

1. Material Change Number (MCN)
2. MWO Number
3. Unit Identification Code (UIC) @ Battalion Level
4. NSN of End Item
5. Serial Number

6. USA Registration Number
7. Date of Application
8. Hours required for Application.
9. Software Version

- (3) For off-line reporting, the 3.5-inch disk shall be mailed to the following address:
Commander
TACOM-Warren
ATTN: AMSTA-LC-CIPWM
Warren, MI 48397-5000

b. Marking Equipment.

- (1) After Airlift Bumper Reinforcement Modification Kit is installed, mark MWO under “9-2320-280-20-6” in the MWO Applied block and date applied in Date block on 10930014 MWO instruction plate.

NOTE

- Do not remove any existing MWO instruction plates affixed to the reinforcement panel.
 - Perform steps 2 and 3 for M1097, M1097A1, M1025A2, M1097A2, M1113, and step 4 for M1114.
- (2) Install MWO instruction plate 10930014 by drilling a 0.104-inch diameter hole (#37 drill bit) within designated area on left side body reinforcement panel and secure with MS21318-20 drive screw as shown in figure 7.
 - (3) After drive screw is installed, flatten or remove protruding excess drive screw material from inside of side body reinforcement panel.
 - (4) Apply versilok adhesive 204 on back of MWO instruction plate 10930014 and install on left side body armor panel as shown in figure 8.

15. MATERIAL CHANGE (MC) NUMBER.

This MWO is authorized by (MC) number 1-00-06-0009.

16. MODIFICATION IDENTIFICATION.

a. When installed correctly, the Airlift Bumper Reinforcement Modification Kit will appear as shown in figure 9.

b. After the Airlift Bumper Reinforcement Modification Kit is installed, the airlift bumper reinforcement should be inspected for secure mounting. Any faults detected, or discrepancies noted, will be corrected before the vehicle is returned to normal service.

c. After the vehicle is modified it will be “AUTHORIZED TO TOW TRAILERS WITH MAX GROSS WEIGHT OF 4,200 LB (1,907 KG)”.

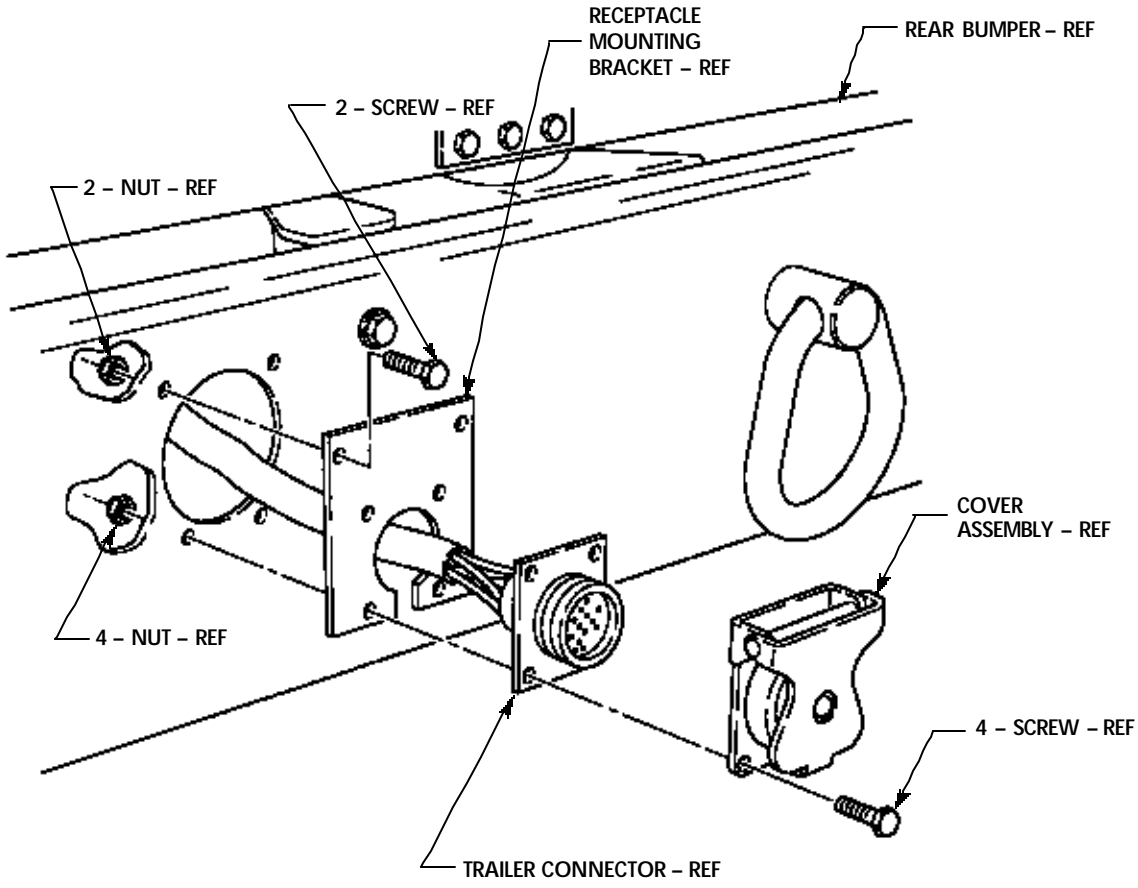
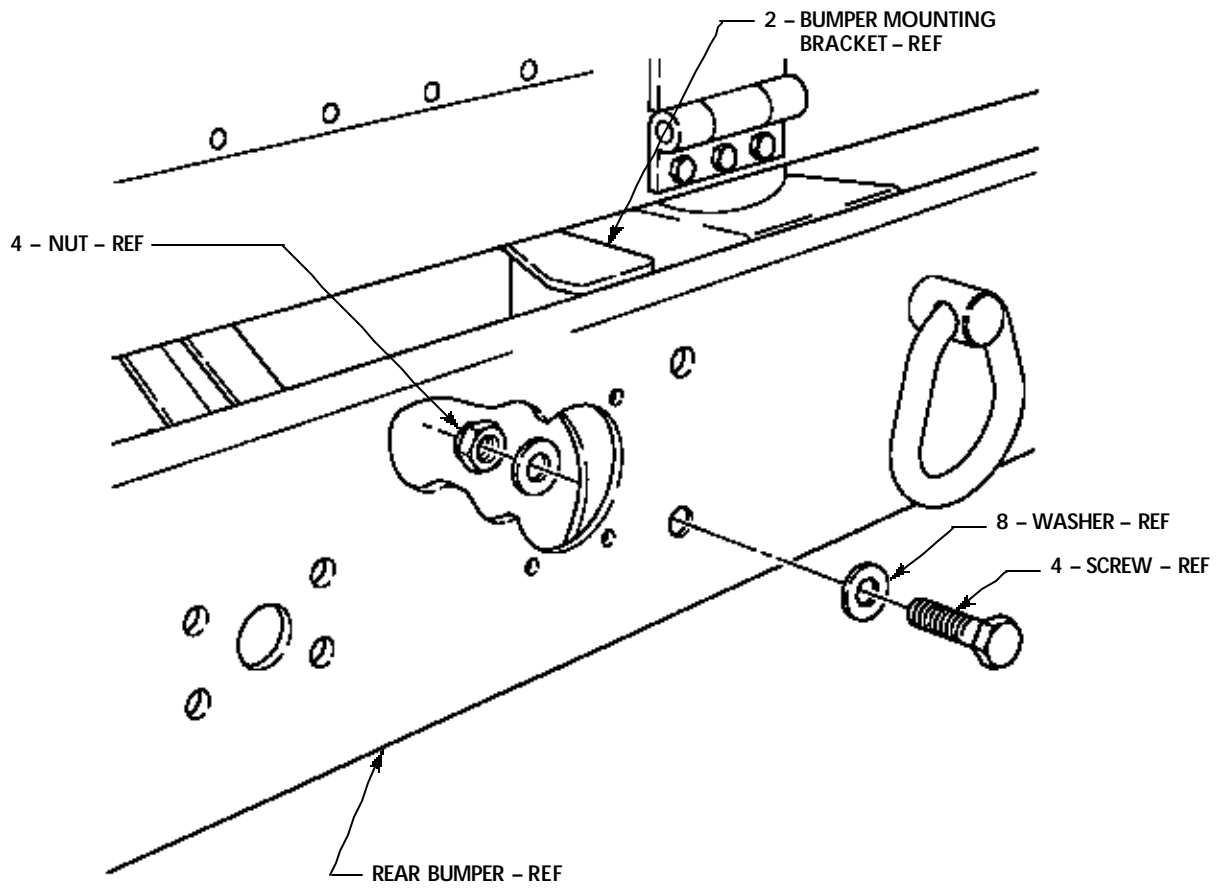

FIGURE 1



RIGHT SIDE SHOWN, LEFT SIDE OPPOSITE

FIGURE 2

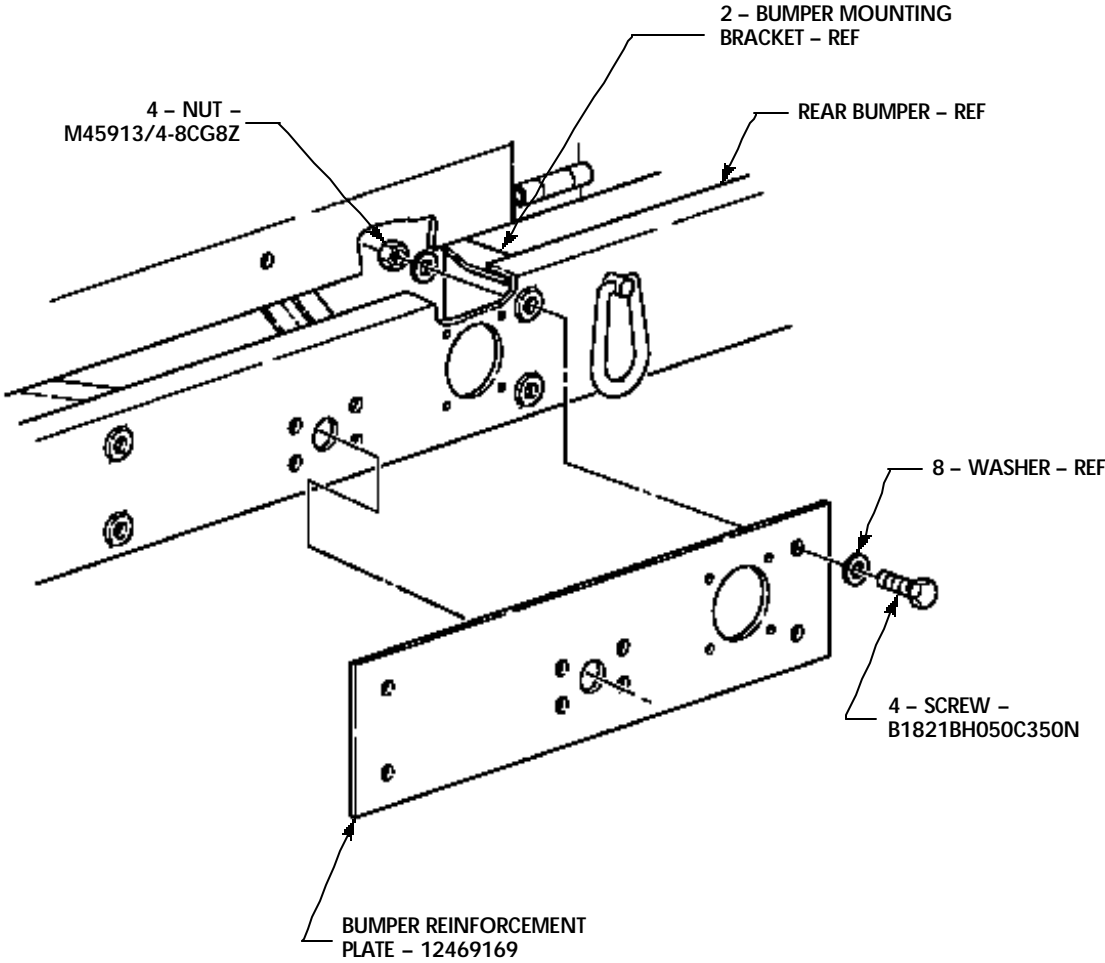

FIGURE 3

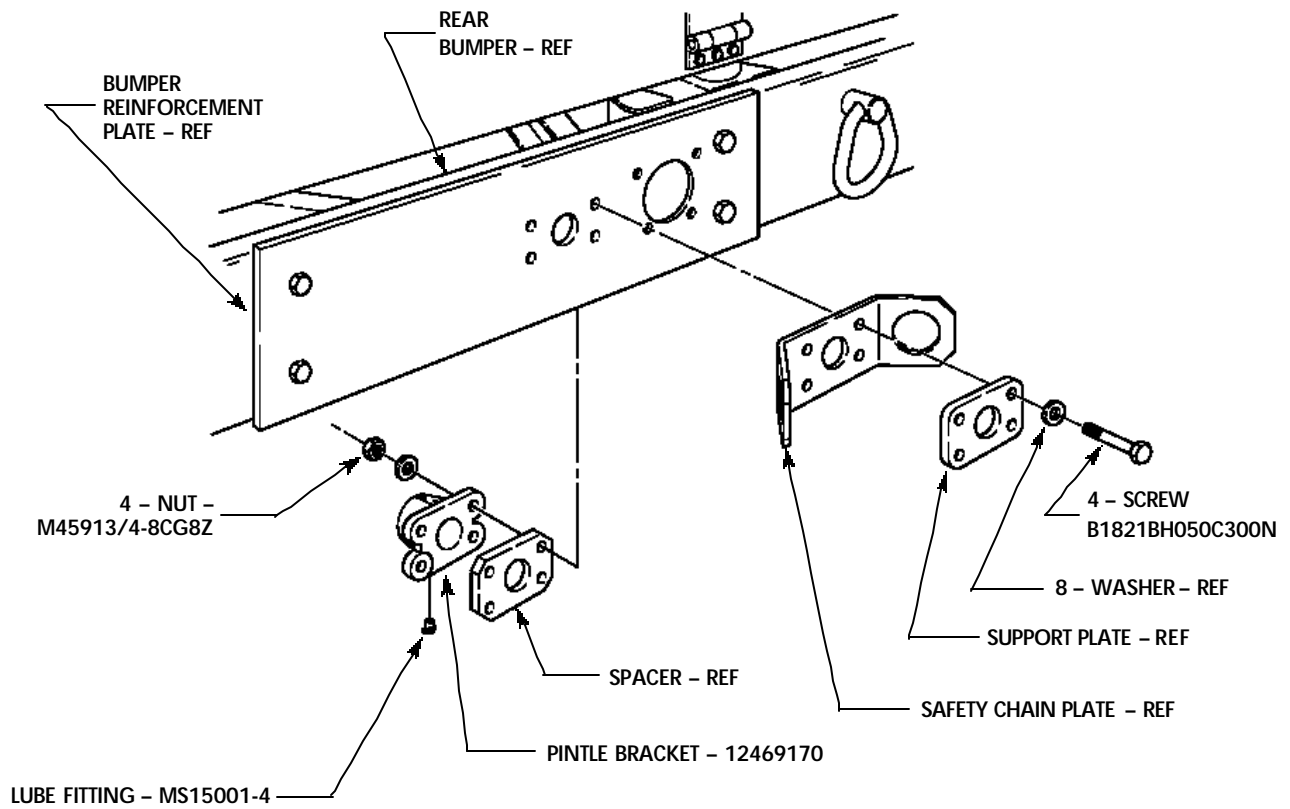

FIGURE 4

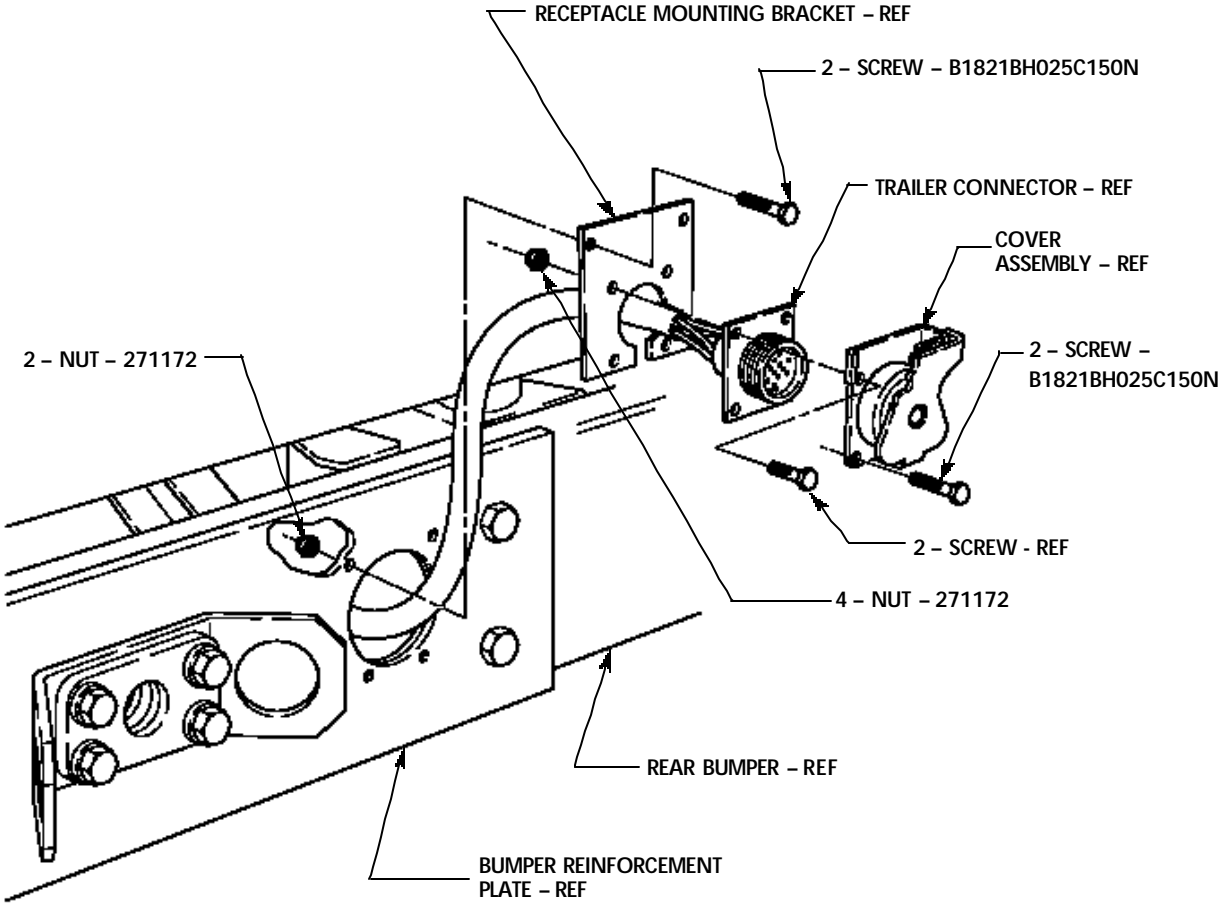

FIGURE 5

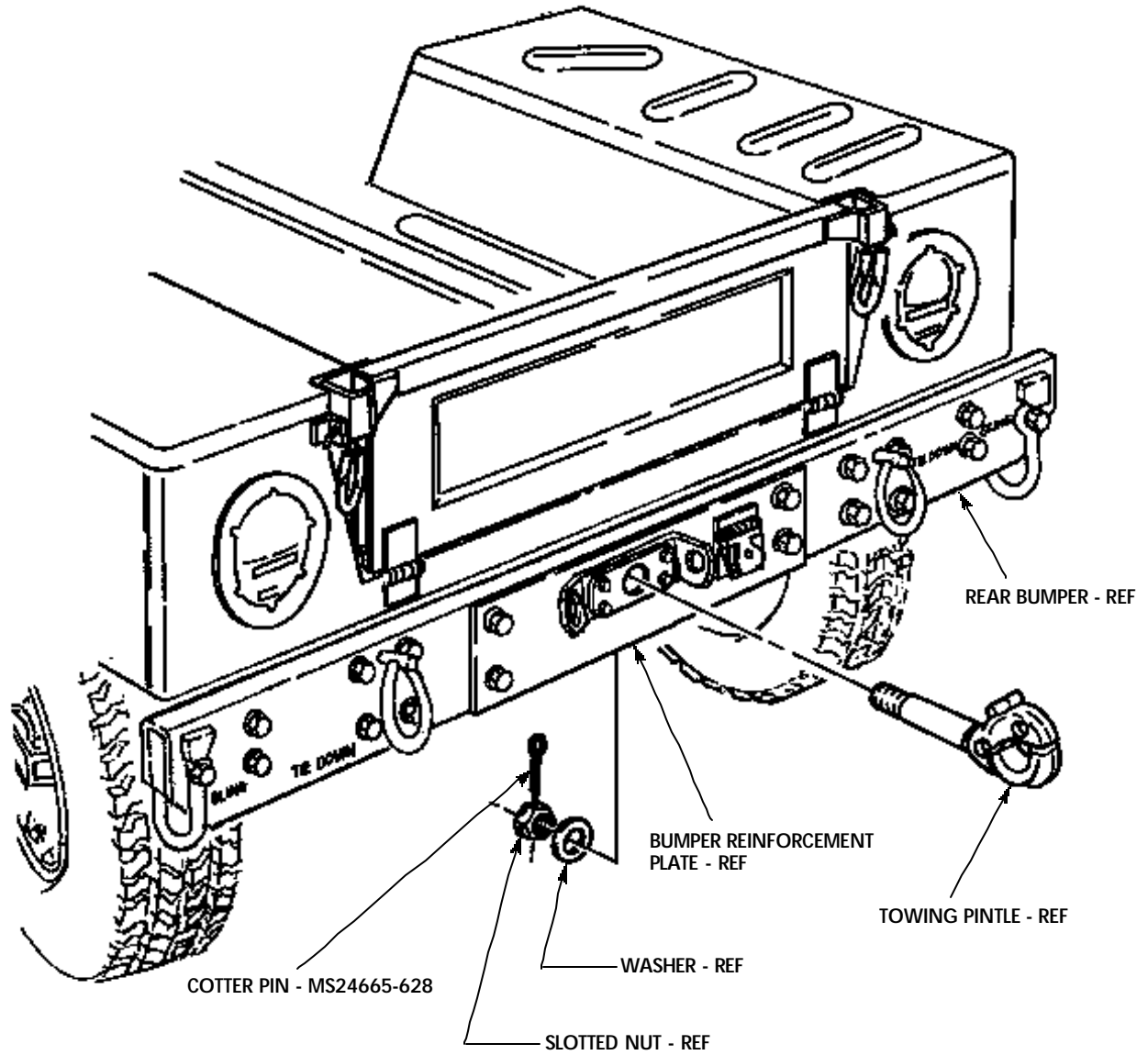

FIGURE 6

NOTE: ALL DIMENSIONS ARE IN INCHES

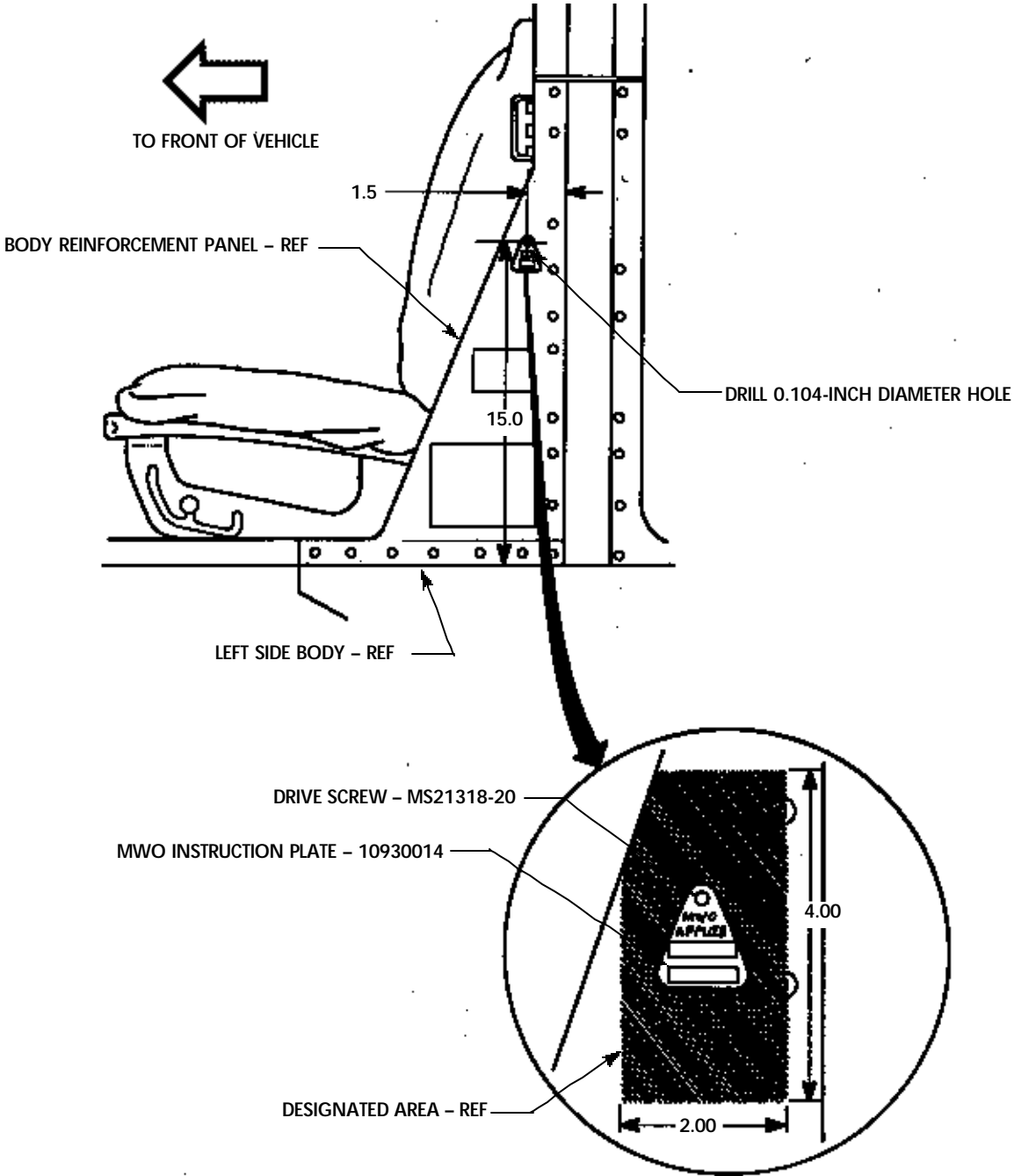

FIGURE 7

NOTE: ALL DIMENSIONS ARE IN INCHES

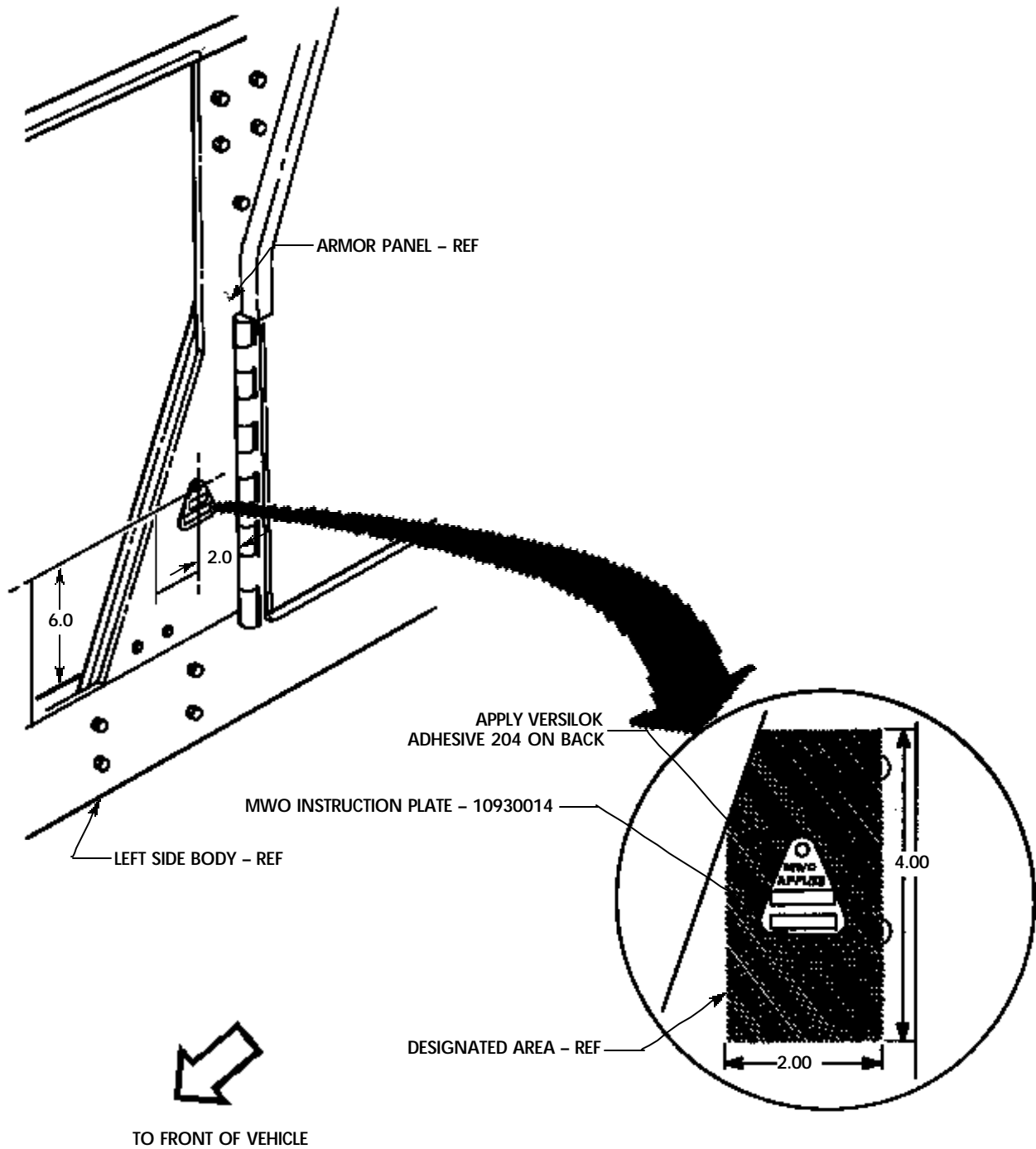
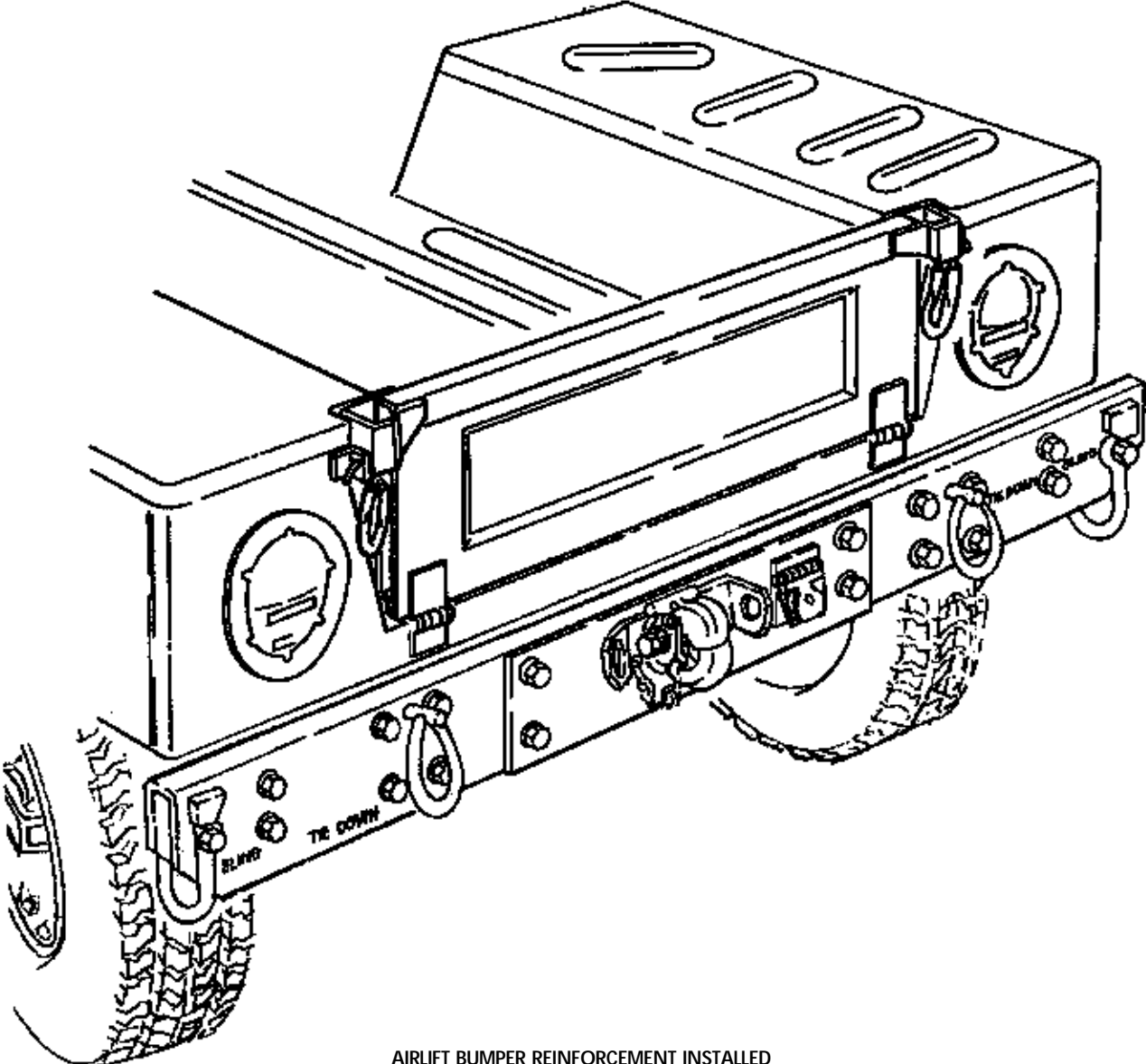

FIGURE 8



AIRLIFT BUMPER REINFORCEMENT INSTALLED

FIGURE 9

By Order of the Secretary of the Army:

ERIC K. SHINSEKI
General, United States Army
Chief of Staff

Official:

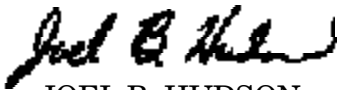

JOEL B. HUDSON
Administrative Assistant to the
Secretary of the Army
0024511

Distribution:

To be distributed in accordance with the initial distribution number (IDN) 381104, requirements for MWO 9-2320-280-20-6.

THE METRIC SYSTEM AND EQUIVALENTS

LINEAR MEASURE

- 1 Centimeter = 10 Millimeters = 0.01 Meters = 0.3937 Inches
- 1 Meter = 100 Centimeters = 1,000 Millimeters = 39.37 Inches
- 1 Kilometer = 1,000 Meters = 0.621 Miles

SQUARE MEASURE

- 1 Sq Centimeter = 100 Sq Millimeters = 0.155 Sq Inches
- 1 Sq Meter = 10,000 Sq Centimeters = 10.76 Sq Feet
- 1 Sq Kilometer = 1,000,000 Sq Meters = 0.386 Sq Miles

CUBIC MEASURE

- 1 Cu Centimeter = 1,000 Cu Millimeters = 0.06 Cu Inches
- 1 Cu Meter = 1,000,000 Cu Centimeters = 35.31 Cu Feet

LIQUID MEASURE

- 1 Milliliter = 0.001 Liters = 0.0338 Fluid Ounces
- 1 Liter = 1,000 Milliliters = 33.82 Fluid Ounces

TEMPERATURE

- $5/9 (^{\circ}\text{F} - 32) = ^{\circ}\text{C}$
- 212° Fahrenheit is equivalent to 100° Celsius
- 90° Fahrenheit is equivalent to 32.2° Celsius
- 32° Fahrenheit is equivalent to 0° Celsius
- $9/5 ^{\circ}\text{C} + 32 = ^{\circ}\text{F}$

WEIGHTS

- 1 Gram = 0.001 Kilograms = 1,000 Milligrams = 0.035 Ounces
- 1 Kilogram = 1,000 Grams = 2.2 Lb
- 1 Metric Ton = 1,000 Kilograms = 1 Megagram = 1.1 Short

APPROXIMATE CONVERSION FACTORS

TO CHANGE	TO	MULTIPLY BY
Inches	Centimeters	2.540
Feet	Meters	0.305
Yards	Meters	0.914
Miles	Kilometers	1.609
Square Inches	Square Centimeters	6.451
Square Feet	Square Meters	0.093
Square Yards	Square Meters	0.836
Square Miles	Square Kilometers	2.590
Acres	Square Hectometers	0.405
Cubic Feet	Cubic Meters	0.028
Cubic Yards	Cubic Meters	0.765
Fluid Ounces	Milliliters	29.573
Pints	Liters	0.473
Quarts	Liters	0.946
Gallons	Liters	3.785
Ounces	Grams	28.349
Pounds	Kilograms	0.454
Short Tons	Metric Tons	0.907
Pound-Feet	Newton-Meters	1.356
Pounds Per Square Inch	Kilopascals	6.895
Miles Per Gallon	Kilometers Per Liter	0.425
Miles Per Hour	Kilometers Per Hour	1.609
TO CHANGE	TO	MULTIPLY BY
Centimeters	Inches	0.394
Meters	Feet	3.280
Meters	Yards	1.094
Kilometers	Miles	0.621
Square Centimeters	Square Inches	0.155
Square Meters	Square Feet	10.764
Square Meters	Square Yards	1.196
Square Kilometers	Square Miles	0.386
Square Hectometers	Acres	2.471
Cubic Meters	Cubic Feet	35.315
Cubic Meters	Cubic Yards	1.308
Milliliters	Fluid Ounces	0.034
Liters	Pints	2.113
Liters	Quarts	1.057
Liters	Gallons	0.264
Grams	Ounces	0.035
Kilograms	Pounds	2.205
Metric Tons	Short Tons	1.102
Newton-Meters	Pound-Feet	0.738
Kilopascals	Pounds Per Square Inch	0.145
Kilometers Per Liter	Miles Per Gallon	2.354
Kilometers Per Hour	Miles Per Hour	0.621

